

INJECTION MOLDING DESIGN GUIDELINES



INJECTION MOLDED PARTS

Injection molding is used for manufacturing a wide variety of parts, from small components like AAA battery boxes to large components like truck body panels. Once a component is designed, a mold is made and precision machined to form the features of the desired part. The injection molding takes place when a thermoplastic or thermoset plastic material is fed into a heated barrel, mixed, and forced into the metal mold cavity where it cools and hardens before being removed.

TOOLING

Mold and die are used interchangeably to describe the tooling applied to produce plastic parts. They are typically constructed from pre-hardened steel, hardened steel, aluminum, and/or beryllium-copper alloy. Of these materials, hardened steel molds are the most expensive to make, but offer the user a long lifespan, which offsets the cost per part by spreading it over a larger quantity. For low volumes or large components, pre-hardened steel molds provide a less wear-resistant and less expensive option.

The most economical molds are produced out of aluminum. When designed and built using CNC machines or Electrical Discharge Machining processes, these molds can economically produce tens of thousands to hundreds of thousands of parts. Note that beryllium copper is often used in areas of the mold that require fast heat removal or places that see the most shear heat generated.

INJECTION MOLDING

The injection molding process uses a granular plastic that is gravity fed from a hopper. A screw-type plunger forces the material into a heated chamber, called a barrel, where it is melted. The plunger continues to advance, pushing the polymer through a nozzle at the end of the barrel that is pressed against the mold. The plastic enters the mold cavity through a gate and runner system. After the cavity is filled, a holding pressure is maintained to compensate for material shrinkage as it cools. At this same time, the

screw turns so that the next shot is moved into a ready position, and the barrel retracts as the next shot is heated. Because the mold is kept cold, the plastic solidifies soon after the mold is filled. Once the part inside the mold cools completely, the mold opens, and the part is ejected. The next injection molding cycle starts the moment the mold closes and the polymer is injected into the mold cavity.

INJECTION MOLDING MATERIALS

Materials Selection: Many types of thermoplastic materials are available. Selection depends on the specific application. The chart below shows some of the most common materials being used.

INJECTION MOLDING ENGINEERED THERMOPLASTIC MATERIALS	
Nylons	Polyphenylene Sulfide PPS
Polycarbonates	Polyether Sulfone
Acetals	Polyetheretherketone PEEK
Acrylics	Fluoropolymers
Polypropylenes	Polyether Imide PEI
Polyethylenes	Polyphenylene Oxide PPO
Acrylonitrile Butadiene Styrene	Polyurethanes PUR
Thermoplastic Elastomers	Polyphthalamide PPA

WALL SECTION CONSIDERATIONS

WALL THICKNESS

Cost savings are highest when components have a mini-mum wall thickness, as long as that thickness is consistent with the part's function and meets all mold filling considerations. As would be expected, parts cool faster with thin wall thicknesses, which means that cycle times are shorter, resulting in more parts per hour. Further, thin parts weigh less, using less plastic per part. On average, the wall thickness of an injection molded part ranges from 2mm to 4mm (.080 inch to .160 inch). Thin wall injection molding can produce walls as thin as .05mm (.020 inch).

UNIFORM WALLS

Parts with walls of uniform thickness allow the mold cavity to fill more easily since the molten plastic does not have to be forced through varying restrictions as it fills.

If the walls are not uniform the thin section cools first, then as the thick section cools and shrinks it builds stresses near the boundary area between the two. Because the thin section has already hardened, it doesn't yield. As the thick section yields, it leads to warping or twisting of the part, which, if severe enough, can cause cracks.

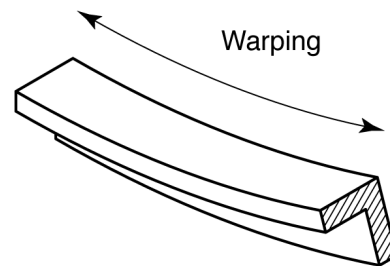

Figure 1:
Uniform wall thickness can reduce or eliminate warping

What if you cannot have uniform walls (due to design limitations)?

If design limitations make it impossible to have uniform wall thicknesses, the change in thickness should be as gradual as possible.



Figure 2: Transition of wall thickness

Coring is a method where plastic is removed from the thick area, which helps to keep wall sections uniform, eliminating the problem altogether.

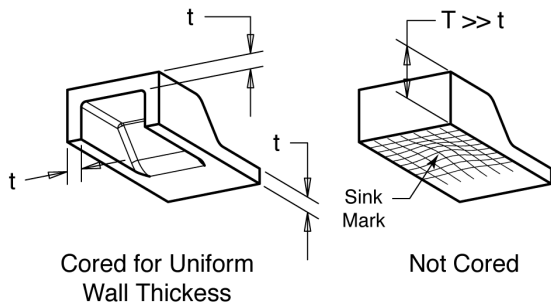

Figure 3: Coring to eliminate sinks

Gussets are support structures that can be designed into the part to reduce the possibility of warping.

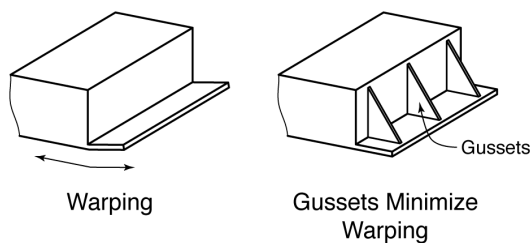

Figure 4: Gusseting to reduce warping

VOIDS AND SHRINKAGE

Troublesome shrinkage problems can be caused by the intersection of walls that are not uniform in wall thickness. Examples might include ribs, bosses, or any other projection of the nominal wall. Since thicker walls solidify slower, the area they are attached to at the nominal wall will shrink as the projection shrinks. This can result in a sunken area in the nominal wall. Such shrinkage can be minimized if a rib thickness is maintained to between 50 and 60 percent of the walls they are attached to. To further our example, bosses located into a corner will produce very thick walls, causing sink, unless isolated as in the illustration below.

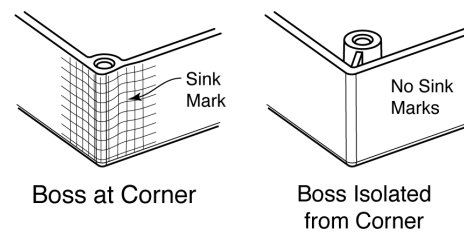

Figure 5: Boss design to eliminate sinks

WARPAGE

The dynamic of thin and thick sections and their cooling times creates warpage as well. As would be expected, as a thick section cools it shrinks, and the material for the shrinkage comes from the unsolidified areas causing the part to warp.

Other causes for warpage might include the molding process conditions, injection pressures, cooling rates, packing problems, and mold temperatures. Resin manufacturers' process guidelines should be followed for best results.

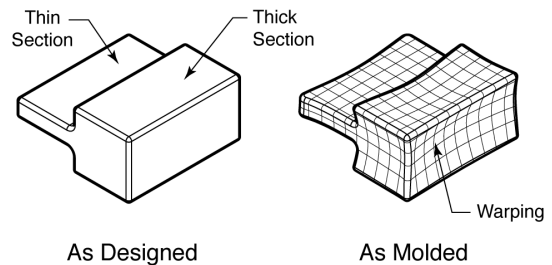

Figure 6: Warpage caused by non-uniform wall thickness

BOSSES

Bosses are used to facilitate the registration of mating parts, for attaching fasteners such as screws, or for accepting threaded inserts.

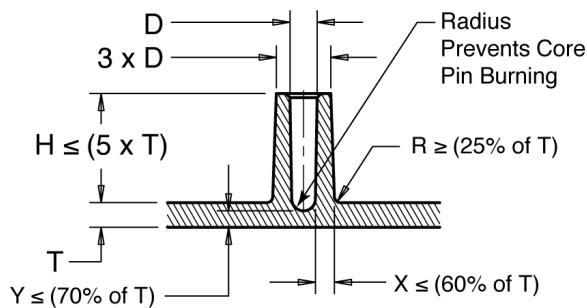

Figure 7: Boss design guidelines

Wall thicknesses for bosses should be less than 60 percent of the nominal wall to minimize sinking. However, if the boss is not in a visible area, then the wall thickness can be increased to allow for increased stresses imposed by self-tapping screws.

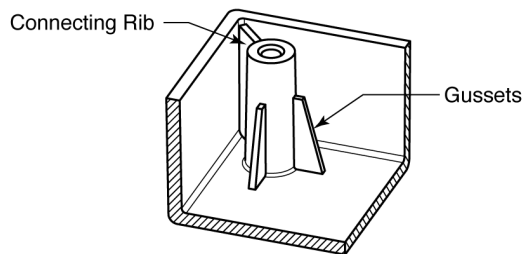

Figure 8: Boss strengthening technique

The base radius should be a minimum of 0.25 X thickness. Bosses can be strengthened by incorporating gussets at the base or by using connecting ribs attaching to nearby walls.



RIBS

Ribs are used in a design to increase the bending stiffness of a part without adding thickness. Ribs increase the moment of inertia, which increases the bending stiffness.

Bending Stiffness = E (young's Modulus) $\times I$ (Moment of Inertia)

Rib thickness should be less than wall thickness to minimize sinking effects. The recommended rib thickness should not exceed 60 percent of the nominal thickness. Plus, the rib should be attached with corner radii as generous as possible.

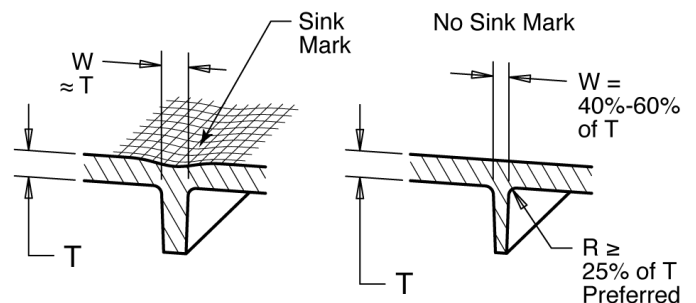

Figure 9: Proper rib design reduces sinking

RIB INTERSECTIONS

Because the thickness of the material will be greater at the rib intersections, coring or another means of material removal should be employed to avoid excessive sinking from occurring on the opposite side.

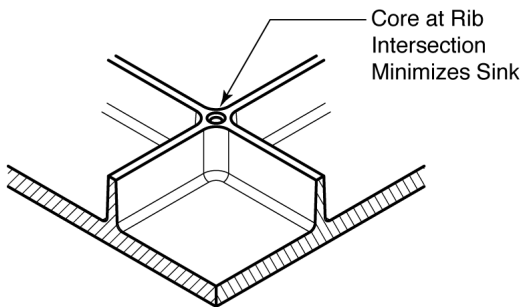

Figure 10: Coring at rib intersections

RIB GUIDELINES

The height of a rib should be limited to less than three times its thickness. It is better to use multiple ribs to increase bending stiffness than to use one very tall rib.

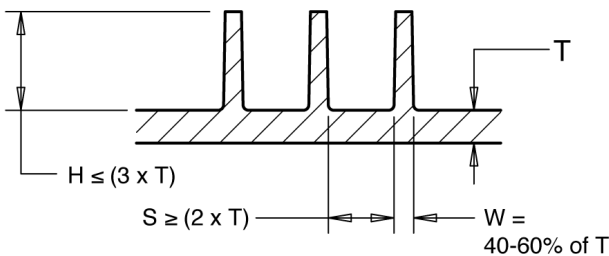

Figure 11: Design guidelines for ribs

RIB/LOAD AFFECT ON STIFFNESS

A rib is oriented in such a way as to provide maximum bending stiffness to the part. By paying attention to part geometry, designers must be conscious of the orientation of the rib to the bending load or there will be no increase in stiffness.

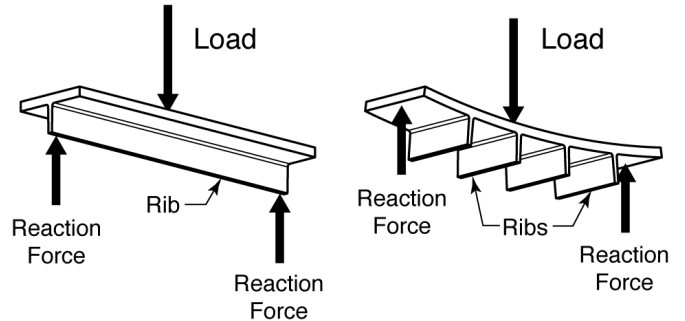

Figure 12: Rib/ load orientation affects part stiffness; Draft angles for ribs should be a minimum of 0.25 to 0.5 degree of draft per side

DRAFT AND TEXTURE

Mold drafts facilitate part removal from the mold. The draft must be in an offset angle that is parallel to the mold opening and closing. The ideal draft angle for a given part depends on the depth of the part in the mold and its required end-use function.

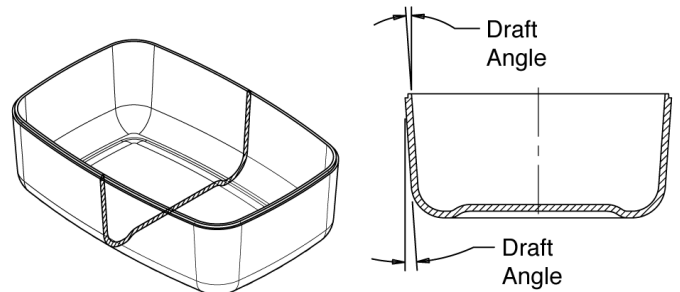

Figure 12: Draft Angle

Allowing for as much draft as possible will permit parts to release from the mold easily. Typically, one to two degrees of drafts with an additional 1.5 degrees per 0.25mm depth of texture is enough to do the trick.

The mold part line will need to be located in a way that splits the draft in order to minimize it. If no draft is acceptable due to design considerations, a side action mold may be required.

TEXTURES AND LETTERING

Whether to incorporate identifying information or to include as an aesthetic addition, textures and lettering can be included onto mold surfaces for the end user or factory purposes. Texturing may also hide surface defects such as knit lines and other imperfections. The depth of the texture or letters is somewhat limited, and extra draft needs to be provided to allow for part removal from the mold without dragging or marring the part.

Draft for texturing is somewhat dependent on the part design and specific texture desired. As a general guideline, 1.5° min. per 0.025mm (0.001 inch) depth of texture needs to be allowed for in addition to the normal draft. Usually for general office equipment such as laptop computers a texture depth of 0.025 mm (0.001 inch) is used and the minimum draft recommended is 1.5°. More may be needed for heavier textured surfaces such as leather (with a depth of 0.125 mm/0.005 inch) that requires a minimum draft of 7.5°.

SHARP CORNERS

Sharp corners greatly increase stress concentration, which, when high enough, can lead to part failure. Sharp corners often come about in non-obvious places, such as a boss attached to a surface, or a strengthening rib. The radius of sharp corners needs to be watched closely because the stress concentration factor varies with radius for a given thickness. As illustrated in the chart to the left, the stress concentration factor is high for R/T values less than 0.5, but for R/T values over 0.5 the concentration lowers. The stress concentration factor is a multiplier that greatly increases stress. It is recommended that an inside radius be a minimum of one times the thickness.

In addition to reducing stresses, the fillet radius provides a streamlined flow path for the molten plastic, resulting in an easier fill of the mold.

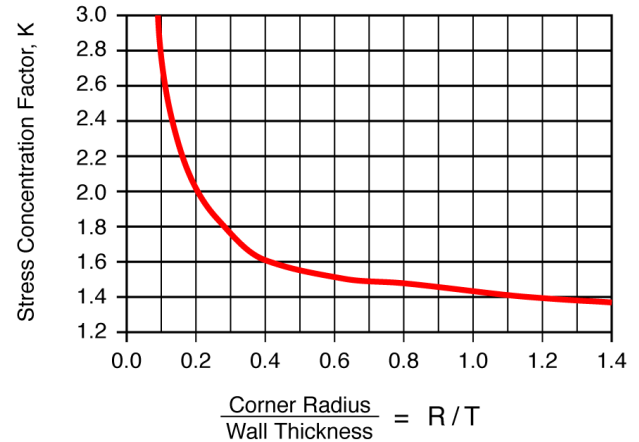

Figure 13: Stress Concentration Factor, K

At corners, the suggested inside radius is 0.5 times the material thickness and the outside radius is 1.5 times the material thickness. A bigger radius should be used if part design allows.

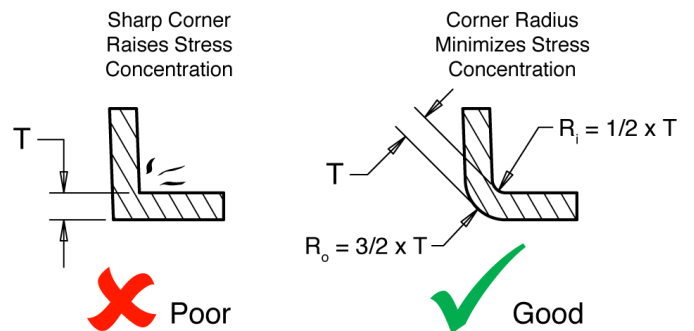

Figure 14: Radius Recommendation

INSERTS

Inserts used in plastic parts provide a place for fasteners such as machine screws. The advantage of using inserts is that they are often made of brass and are robust. They allow for a great many cycles of assembly and disassembly. Inserts are installed in injection molded parts using one of the following methods:

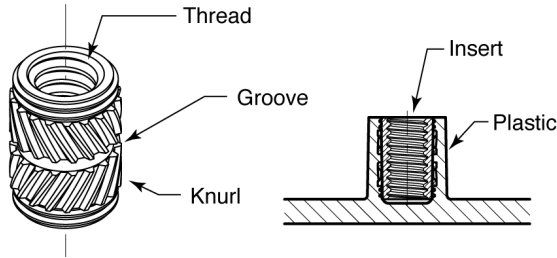

Figure 15: Threaded Insert

LIVING HINGES

Living hinges are thin sections of plastic that connect two segments of a part to keep them together and allow the part to “hinge” open and closed. Typically these hinges are incorporated in containers that are used in high volume applications such as toolboxes and CD cases.

ULTRASONIC INSERTION

Ultrasonic insertion is when an insert is “vibrated” into place by using an ultrasonic transducer called the “horn” that is mounted into the ultrasonic device. For optimum performance, the horn is specially designed for each application. Ultrasonic energy is converted to thermal energy by the vibrating action, which allows the insert to be melted into the hole. This type of insertion can be done rapidly, with short cycle times, and low residual stresses. Good melt flow characteristics for the plastic is necessary for the process to be successful.

THERMAL INSERTION

This method uses a heated tool, like a soldering iron, to first heat the insert until it melts the plastic, and then presses the insert into place. As the plastic cools it shrinks around the insert, capturing it. The advantage of this method is that the special tooling is inexpensive and simple to use. Care does need to be taken not to overheat the insert or plastic, which could result in a non-secure fit and degradation of the plastic.

MOLDED-IN

To mold inserts into place during the molding cycle, core pins are used to hold the inserts. The injected plastic completely encases the insert, which provides excellent retention. This process may slow the molding cycle because inserts have to be hand loaded, but it also eliminates secondary operations such as the ultrasonic and thermal insertion methods. Finally, for high volume production runs, an automatic tool can load the inserts but this increases the complexity and cost of the mold.

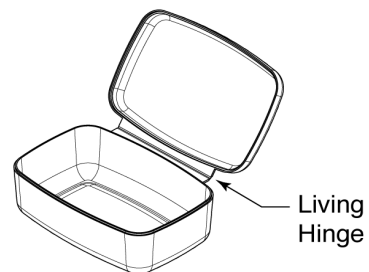

Figure 16: Box with Living Hinge

Materials used in molding living hinges must be very flexible, such as polypropylene or polyethylene. A well-designed living hinge typically flexes more than a million cycles without failure.

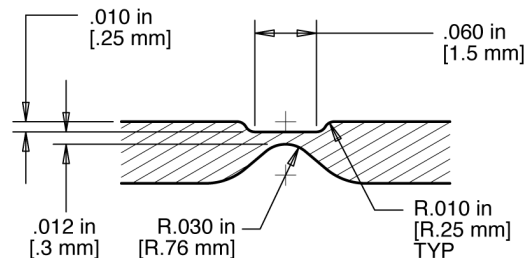

Figure 17:
Living Hinge Design for Polypropylene and Polyethylene



GAS ASSIST MOLDING

This process is used to hollow out thick sections of a part where coring is not an option and sink is not acceptable. Gas assist molding can be applied to almost any thermoplastic, and most conventional molding machines can be adapted for gas assist molding.

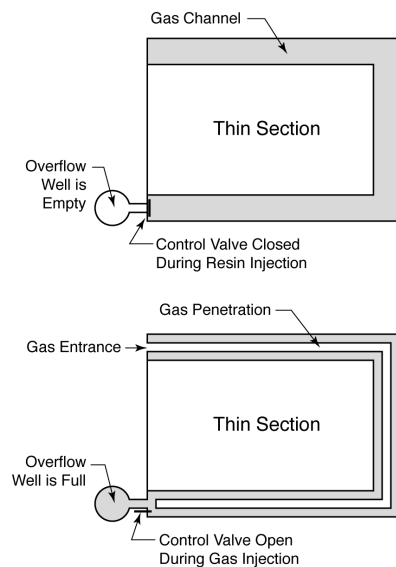

Figure 18: Gas Assist Molding

OVERMOLDING

The overmolding process is when a flexible material is molded onto a more rigid material called a substrate. If properly selected, the overmolded (flexible material) will form a strong bond with the substrate. Bonding agents are no longer required to achieve optimum bond between the substrate and overmold.

INSERT MOLDING

The most widely used overmolding process is insert molding. This is where a pre-molded substrate is placed into a mold and the flexible material is shot directly over it. The advantage of this process is that conventional, single shot injection molding machines can be used.

TWO SHOT MOLDING

This is a multi-material overmolding process that requires a special injection molding machine that incorporates two or more barrels. This allows two or more materials to be shot into the same mold during the same molding cycle. The two shot molding is usually associated with high volume production of greater than 250,000 cycles.